



CARBIDE TIPPED SPECIALS QUOTE FORM

REQUIRED INFORMATION FOR QUOTING AND ORDERING
 FAX TO 573-221-1140 or E-MAIL TO sales@hannibalcarbide.com

TECHNICAL

CARBIDE TIPPED - SHANK TYPE TOOLS

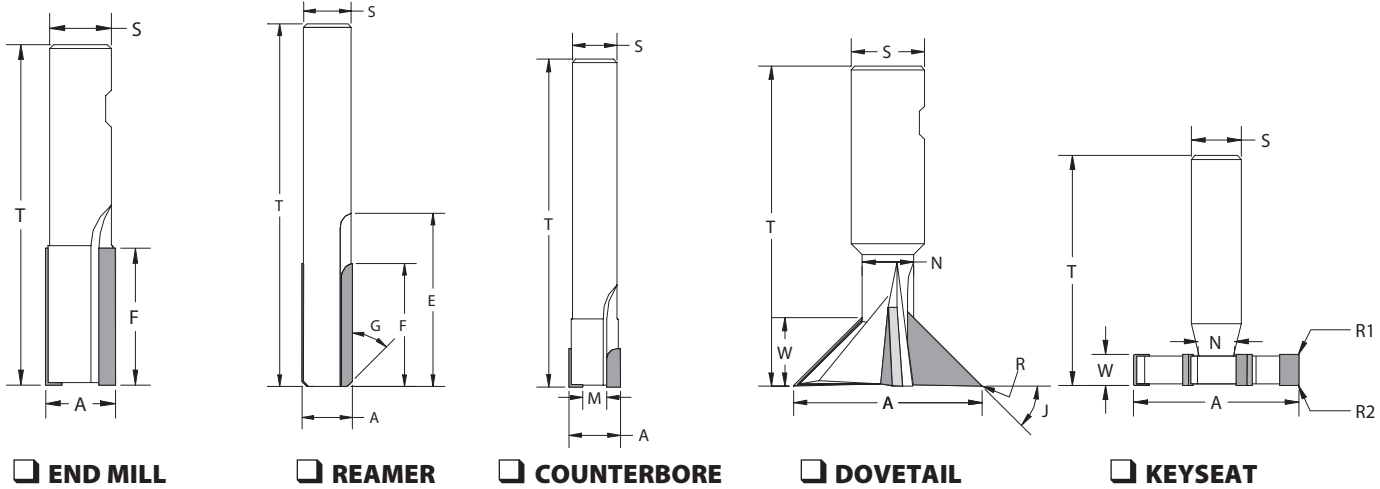

END MILL

REAMER

COUNTERBORE

DOVETAIL

KEYSEAT

QUOTE REQUEST FORM:

INDIVIDUAL: _____

COMPANY: _____

CITY/STATE: _____

FAX #: _____ PHONE #: _____

QUANTITY BREAKS: _____ pcs _____ pcs _____ pcs _____ pcs

Chip class of MATERIAL BEING MACHINED (from page 6-8)

20 40 60 80 100 120 140 Other Material _____

BODY OF TOOL

T= _____ Overall Length S= _____ Shank Diameter A= _____ Major Diameter
 G= _____ ° Chamfer Angle

FLUTES

E= _____ Flute Length F= _____ Carbide Length
 Straight Flutes Number of Flutes _____
 Right Hand Cutting Right Hand Spiral _____ °
 Left Hand Cutting Left Hand Spiral _____ °

IF PILOTED

Cutting Pilot Head Diam. _____ Non-Cutting Pilot Head Length _____
 M= Min. Cutting Diam. _____

IF STEP REAMER

Cutting Step Non-Cutting Step
 (Also see pages 95-97) Minor Diam. _____ Step Length _____ Step Angle _____ °

IF KEYSEAT

W= _____ Width Straight Tooth R1= _____ Radius/Chamfer
 N= _____ Neck Diameter Staggered Tooth R2= _____ Radius/Chamfer

IF DOVETAIL

N= _____ Neck Diam. J= _____ ° Angle R= _____ Radius W= _____ Width

ADDITIONAL APPLICATION NOTES: _____

Special order tool quotes usually same day; always next. Over 96% of Special tool orders shipped on promise date.